

INNOVATION SCIENCE AND TECHNOLOGY



Scopus || Electronic journal specializing in Scopus

ISSUE 8

 Acceptance of papers **August, 2025**



**Acceptance of
papers**

Published monthly



Topics

economics,
technology, social
sciences



EDITOR-IN-CHIEF:

Mirzaliev Sanjar Makhmatjon ugli

DEPUTY EDITOR-IN-CHIEF:

Makhmudov Nosir Makhmudovich
DSc., Prof., Academician

DEPUTY EDITOR-IN-CHIEF:

Ochilov Bobur Bakhtiyor ugli – Senior
lecturer at TSUI

THE SCIENTIFIC-POPULAR ELECTRONIC
JOURNAL **"INNOVATION SCIENCE AND
TECHNOLOGY"** HAS BEEN REGISTERED
UNDER THE NUMBER **C-5669633** BY THE
AGENCY FOR INFORMATION AND MASS
COMMUNICATIONS (AOKA) OF THE
REPUBLIC OF UZBEKISTAN, EFFECTIVE
FROM OCTOBER 9, 2024.

CONTACTS

Phone: **97-748-70-03**

Website: <https://ist-journal.uz>

Email: munis.iriskulova@gmail.com

The scientific electronic journal "Innovation Science and Technology" has been included in the list of scientific publications recommended for the publication of main scientific results of dissertations for the award of PhD and DSc degrees in economics and technical sciences, in accordance with the Resolution No. 370 of the Presidium of the Higher Attestation Commission of the Republic of Uzbekistan, dated May 8, 2025.

Editorial board:



Sharipov Kongiratbay Avezimbetovich,
Doctor of Technical Sciences (DSc), Professor



Abdurakhmanova Gulnora Kalandarovna,
Doctor of Economic Sciences (DSc), Professor



Cham Tat Huei,
Doctor of Philosophy (PhD), Professor (Malaysia)



Muhammad Imran Sadiq
Doctor of Philosophy in Economics (PhD),
Professor, Malaysia



Ahmed Aziz Ismail
Doctor of Technical Sciences (DSc),
Professor (Egypt)



Lee Chin
Doctor of Philosophy in Economics (PhD),
(Malaysia)



Asongu Simplicé
Doctor of Philosophy in Economics (PhD),
Cameroon



Rui Dang
Doctor of Chemistry (DSc), Professor, China



Zahoor Ahmed
Doctor of Philosophy in Economics (PhD), Turkey



Shujaat Abbas
Doctor of Philosophy in Economics (PhD), Russia



Tina A Coffelt
Doctor of Philosophy in Educational Sciences
(PhD), USA



Judy B. Smetana
Doctor of Philosophy in Economics (PhD), USA

CONTENTS

Socio-economic mechanisms for assessing the impact of green economy development on production resources.....	6
Fattoyev Dilshod	
Enhancing customer loyalty through eco-marketing strategies.....	10
Rahmatov Dilshod Shermat o'g'li	
Model and methods for enhancing the efficiency of mechatronic system modules used in the moistening process within wheat processing systems	15
Qamariddinov Shohruh Akmal o'g'li	
Factors affecting the strength of the resource base of commercial banks.....	26
Rakhmanov Ilkhom Khurramovich	
A comparative study on the convergence and accuracy of numerical integration methods.....	31
Jumaboyev Asadbek Shokirjon ugli	
Institutional foundations for the development of equity circulation in Uzbekistan	34
Quvondiqov Muhammad	
Development of the metal market in the Tashkent region and the role of small businesses in it	38
Usmonova Dिल्фуза Ilkhomovna	
Application of a linear programming problem to analyze the state of a company's commodity and raw material resources.....	43
Musayeva Shoirazimovna	
Improving the financing mechanisms of innovation activity in the construction materials manufacturing sector.....	48
Ilhom Akramovich Gulamov	
Financial literacy and the interaction with financial Policy: An analysis of Uzbekistan and international experience.....	53
Irgashev Anvar Farxodovich	
Cooperation relations between Uzbekistan and Arab (Muslim) countries	57
Jalilov Mehroj Erkin ugli, Prof. Dr. H. Nugraha, S.E., M.Si., Akt. CA., Umarova Zulayho Tursunova	
Technological indicators and operating principle of an improved wool cleaning machine	62
Ibrokhim Ismoyilov, Elyor Quidoshev, Furkat Ismoyilov and Juramirza Qayumov	

TECHNOLOGICAL INDICATORS AND OPERATING PRINCIPLE OF AN IMPROVED WOOL CLEANING MACHINE

Ibrokhim Ismoyilov, Elyor Quldoshev, Furkat Ismoyilov and Juramirza Qayumov

Bukhara state technical university, Bukhara, Uzbekistan

E-mail: ismoyilovfurqat@mail.ru

Abstract: In the article wool fiber cleaning in technology defects Wool initial work in the process cleaning of the car new construction illuminated. Proposal being done cleaning of the car fertility determination formula explained. The machine work mode studied. Improved to clean - to clean to the car various dense wool raw materials samples experience tests take gone. Taken visited in experiments raw material density three types of $\rho = 45,50,55 \text{ kg/m}^3$ The samples were used. The experimental results are presented in graphs showing the dependence of cleaning efficiency.

Key words: wool cleaning machine, fiber processing, technological indicators, cleaning efficiency, mechanical cleaning, wool impurities removal, textile machinery, operational principle, machine modernization, productivity improvement, fiber quality, wool industry, innovation in textile equipment.

INTRODUCTION

Currently, the improvement of cleaning machines at primary processing enterprises for natural fibers is one of the main tasks facing scientists in the field. In particular, it is necessary to modernize the production of machines designed to clean unwashed wool fibers used in the primary processing technology of wool fibers. The disadvantages of currently used wool cleaning machines are that wool fibers are damaged on the feed rollers, active impurities increase as a result of the crushing of large impurities in them, it is difficult to separate wool fibers from the piles of the pile drum, and as a result of the clogging of impurities between the combs, the combs are not completely cleaned of them, which leads to a decrease in the natural properties of the fibers. The purpose of improving this 2BT-150 Sh wool scouring machine is to effectively clean and remove impurities from the wool raw material, increase the level of scouring by evenly distributing the raw material across the working surfaces of the machine, reduce fiber damage by separating wool fibers stuck to the pile drums, and optimize the scouring and cleaning efficiency of the machine.

The task is to provide a wool fiber cleaning machine with a feeding belt, feeding rollers, pile drums and grates located under them, in addition to the feeder belt, feeder rollers, pile drums and grates, movable separators (otsekateli) are installed between the two pile drums at the top and bottom, and one of the grate supports is movable. The movable separator at the top receives its proportional (соответствующее) movement from the movable grooved roller through a lever mechanism, and the direction of the helical surfaces on them is opposite.

The process is as follows: the wool is spread out on a moving supply belt and fed between the corrugated rollers. Since the wool pieces come in different masses (thicknesses), the upper corrugated roller is mounted in a movable position, so that the large mass of wool does not get stuck between the corrugated rollers and does not block the masses coming from behind. The wool is compressed between the rollers and forms a layer, the piles of the pile drum strike this layer, separating small pieces and moving them on the surface of the grate, shaking them to separate the impurities contained in the wool and throwing them from the grate to the dirt-collecting belt at the bottom of the machine. This process takes place between the first pair of pile drums and grates, then passes to the second pair and repeats the cleaning process. However, wool that comes in large masses is not completely crushed (broken up) and is not cleaned when it passes to the second drum, and is discharged from the machine without being completely cleaned. As a result, the cleaning effect of the machine is low. It is clear that in order to increase the cleaning effect, it is necessary to return the wool that has not been separated and is not sufficiently combed to the first combed grid for reprocessing. To do this, when the upper separator is turned to the right, the large wool pieces from the first drum pile are returned to the combed grid for re-combination. This process is repeated until the wool pieces reach the standard size. If the fiber bundles jam between the pile drum and the combed grid, the spring under the grid is compressed, and as a result, the

gap between the drum and the grid increases, allowing the fibers to pass through. The lower driven separator is adjusted (by moving it up and down) according to the dirtiness of the wool being cleaned.

MATERIALS AND METHODS

The machine works as follows. The wool pieces are divided into as many parts as possible by hand and spread out on the supply chute 1, which is compressed between the grooved roller 2 and the driven grooved roller 3 and fed to the drum with a pile 4. The piles pick up the bundles of fibers from the compressed pieces and strike them on the working edge of the piles on the surface of the grate 5, as a result of which the impurities stuck to the fibers are separated from the grates and thrown into the dirt collecting section at the bottom of the machine (Fig. 1).

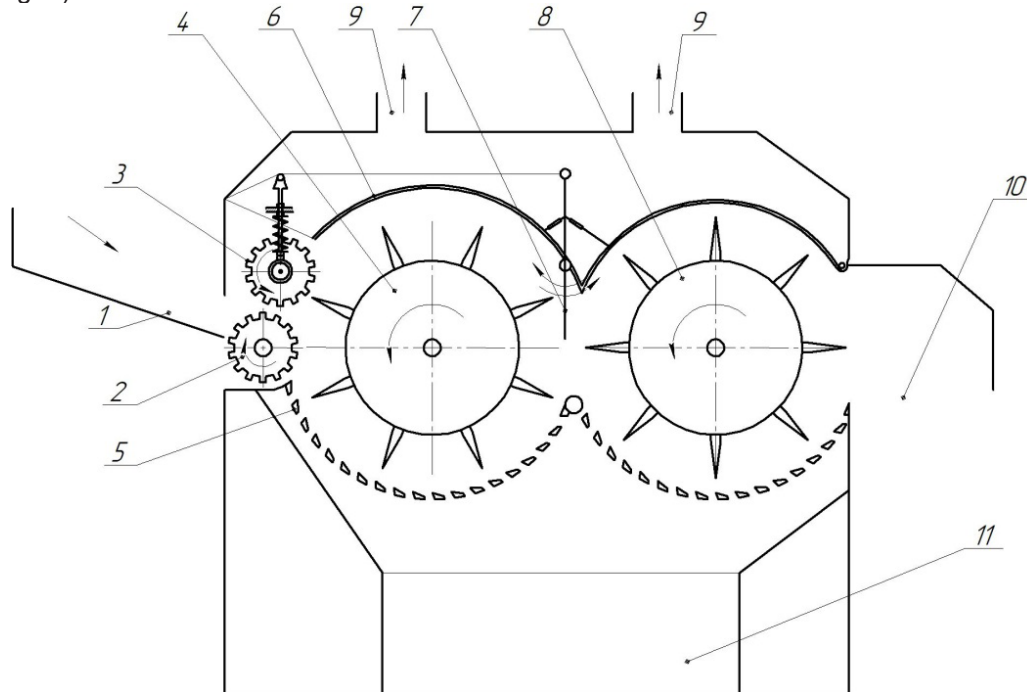

Figure 1. Cross-sectional view of the proposed cleaning machine.

1- feeder ; 2-grooved roller; 3-movable grooved roller; 4,8- pile drums; 5- grate ; 6- mesh surface ; 7 - exciting separator; 9- dust air outlet pipe ; 10 - raw material outlet section, 11- impurities bunker.

For the experiment, the effect of wool on the supply rollers at different densities of wool raw materials, the change in the gap between the rollers, the effect on the flow rate of the rollers, and the effect on the cleaning efficiency and productivity while maintaining the natural quality of the raw materials were determined during the experiment. Tasks assigned to the design of the improved feeder mechanism:

to ensure that wool of different densities passes through the feeder;

prevent wool of different densities from getting tangled in feeders;

Control the distribution of raw materials on the supply rollers according to the working width of the machine.

In the experiment, the number of revolutions of the lower grooved roller is found by the following formula:

$$n = \frac{30v}{\pi R} = \frac{30 \cdot 0,2}{3,14 \cdot 53 \cdot 10^{-3}} = 36 \frac{\text{rot}}{\text{min}} \cdot 3,1$$

We determine the linear velocity of the fluted feed roller using the following formula:

$$v = \frac{\pi n R}{30} = \frac{3,14 \cdot 36 \cdot 0,053}{30} = 0,1997 \approx 0,2 \frac{\text{m}}{\text{s}} \cdot 3,2$$

The frequency of rotations is determined by the following formula:

$$n_{dv} = n_{rvak} \cdot n_{red}$$

where: n_{dv} – is the number of engine revolutions;

number of revolutions n_{rvak} – of the fluted roller ;

n_{red} – number of reductor transmissions;

$$n_{dv} = \frac{1500}{10} = 150 \frac{rot}{min}$$

Inverter Hz unity in determining following proportion We use.

$$1480 \frac{rot}{min} = 50 \text{ Hz}$$

$$150 \frac{rot}{min} = [x] \text{ Hz}$$

where $1480 \frac{rot}{min}$ is the actual engine speed, 50 Hz is the inverter's high speed, $150 \frac{rot}{min}$ The inverter needs to be determined in Hz.

For this we use the following expression;

$$x = \frac{150 \cdot 50}{1480} = 5 \text{ Gts}$$

The rotation speed of the lower shaft on the inverter display 5 Gts $36 \frac{rot}{min}$ and its linear velocity $0,2$ was m/s.

We determine the machine's productivity using the following formula:

$$Q = v \cdot h \cdot \ell \cdot \rho \cdot 3600;$$

The experiment was conducted at three different rotational speeds of the fluted roller and three densities of the wool raw material.

Experimental results showed that the efficiency of the device increased due to the increase in the linear speed of the corrugated roller with the help of an inverter at three different speeds. This is a good indicator, but the cleaning efficiency of the wool raw material decreased slightly. If the linear speed of the corrugated roller was $v=0.15$, the amount of wool raw material passed through the device decreased by almost 2 times, but the cleaning efficiency of the wool increased. When the linear speed of the corrugated roller with the help of an inverter was $v=0.25$, the efficiency of the device increased significantly, but the cleaning efficiency became very low.

The machine's efficiency and the inversely proportionality of the cleaning efficiency of the wool were revealed. At the same time, taking into account the density of the wool at 50 kg/m^3 . we consider the following result to be the optimal solution.

$$Q = 0,2 \cdot 40 \cdot 10^{-3} \cdot 0,5 \cdot 50 \cdot 3600 = 720 \frac{kg}{s};$$

But the improvement of the feeding part of the machine is shown in Figure 2, and its operation is as follows. Along the width of the feeding chute 1, the wool pieces are spread in different layers, between the corrugated rollers 2, 3, the wool pieces are compressed and fed to the drum with a pile to remove wool tufts of different masses from the wool pieces of different sizes. It is known that larger pieces are compressed more strongly, a piece of such pieces is pulled out by the pile. That is, a large piece is broken in this way. But such pieces are still large and it is difficult to separate impurities from them. Therefore, the pieces must be returned to this drum with a pile for repeated processing. This task is performed by the feeding adjustment mechanism.

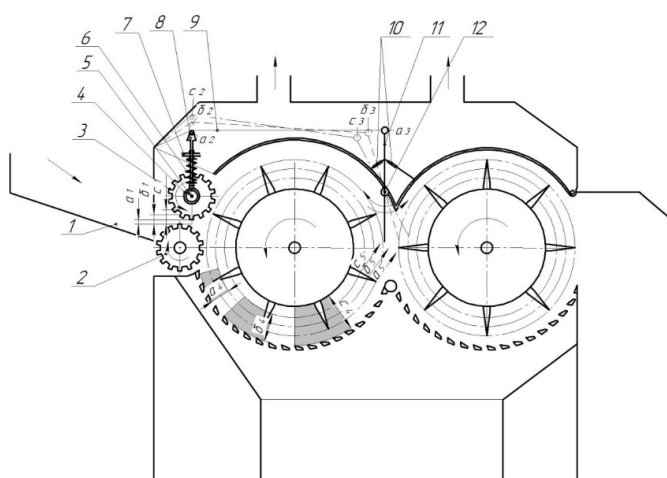

Figure 2. Operation of the controlled supply device in the proposed cleaning machine.

1- feeder ; 2-grooved roller; 3-driven grooved roller; 4- upper roller shaft ; 5- roller bearing ; 6- compression spring ; 7 - spring holder ; 8- roller screw ; 9-wire rope, 10- adjusting springs, 11 -separator, 12-hinge.

The bearing 5, fixed to the shaft 4 of the upper grooved roller, is arranged in such a way that it can only move up and down. If the height of the raw material layer is more than 10 mm, it rises up. To compress the roller down, the bearing is pressed from the top by a spring 6. The spring is attached to the bearing from below, and from the top to the spring holder 7 to the housing. A screw is passed through the spring, which holds the bearing, and its lower part is attached to the bearing, and its upper part is attached to the roller 8 with a thread.

One end of the roller is attached to the machine frame and the other end is attached to the upper part of the separator 9. The separator consists of upper and lower parts and is attached to a hinge 12 in the middle.

In the experiment, the wool raw material available at the enterprise was used. According to it, the density of the raw material was 3 different $\rho = 45, 50, 55 \text{ kg/m}^3$ samples were used. Initially, the distance between the supply rollers was adjusted to be 1-2 mm without touching each other. The compression force of the upper roller is adjusted by a spring. In this case, if the nut above the spring is turned downward, the compression force increases. If the compression force needs to be reduced, the opposite is true.

$\rho = 45 \text{ kg/m}^3$, determined by experiments, was fed into a feeder moving at different speeds. In the process of observing the shaking of the raw material in the pile drum section and the movement of the separator, it became clear that the productivity of the machine was significantly lower. When the raw material layer was of size a_1 , the position of the adjusting separator installed in the machine remained unchanged in the cases a_2, a_3 .

Experiments $\rho = 50 \text{ kg/m}^3$ was carried out on raw material with a density of. According to it, the roller speed was carried out in two variants, namely $v = 0.15, v = 0.2$ and $v = 0.25$. In the experiment, the effect of the separator designed in the upper part of the pile drums on the raw material was observed. Only when the rollers supplying raw material with this density were passed at a speed of $v = 0.25$, part of the raw material hit the separator and was repeatedly cleaned in the first drum (Figure 2).

Then $\rho = 55 \text{ kg/m}^3$ When the raw material of the density is passed through the supply rollers, the roller screw occupies the highest position c_2 when the distance between the rollers is c_1 (see Fig. 2). When the separator is in position c_3 , the raw material c_5 moves in the direction c_5 and almost all of it is affected by the separator and is transferred to repeated cleaning. As a result, the wool raw material is spread between the pile drum and the grate in a layer c_4 .

Results and discussion

The advantage of this proposed controllable supply device is that it allows for efficient cleaning of wool of different densities.

Figure 1,2,3 show the dependence of the cleaning efficiency of the distance between the rollers, the rotation speeds of the rollers, and the rotation speeds of the pile drum. Three curves $y=y(x)$ are given. The first curve is at the minimum, the second at the intermediate point, and the third at x_2 and x corresponds to the maximum value of the 3 factors.

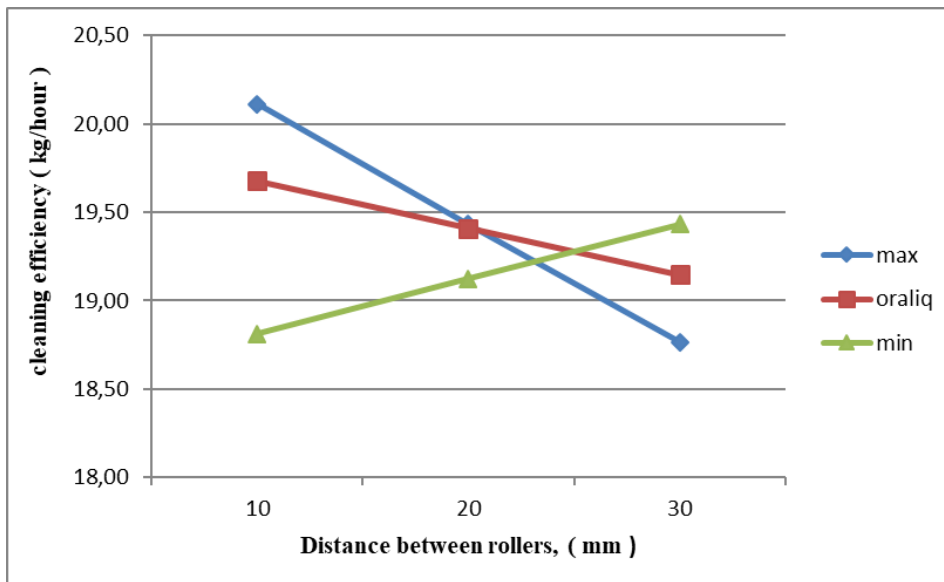

Figure 3. The distance between the rollers cleaning efficiency dependence graph.

In the figure, it can be seen that under the influence of the distance between the rollers and the cleaning efficiency, the machine cleaning efficiency in the first line decreased from 20.1 kg/h to 18.7 kg/h, in the second intermediate line from 19.6 kg/h to 19.1 kg/h, and in the third line increased from 18.8 kg/h to 19.4 kg/h.

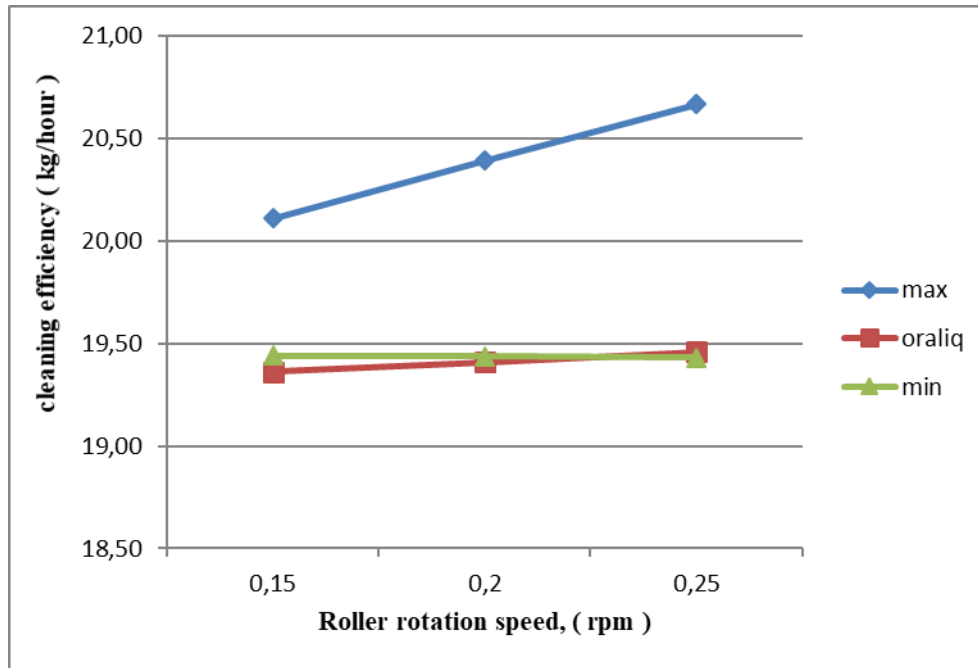

Figure 4. Graph of the dependence of the roller rotation speed on the cleaning efficiency.

Figure 4 shows a graph of the dependence of the roller rotation speed on the cleaning efficiency, in which the first line increases from 20.1 kg/h to 20.6 kg/h, in the second line from 19.3 kg/h to 19.4 kg/h, and in the third line decreases from 19.44 kg/h to 19.43 kg/h.

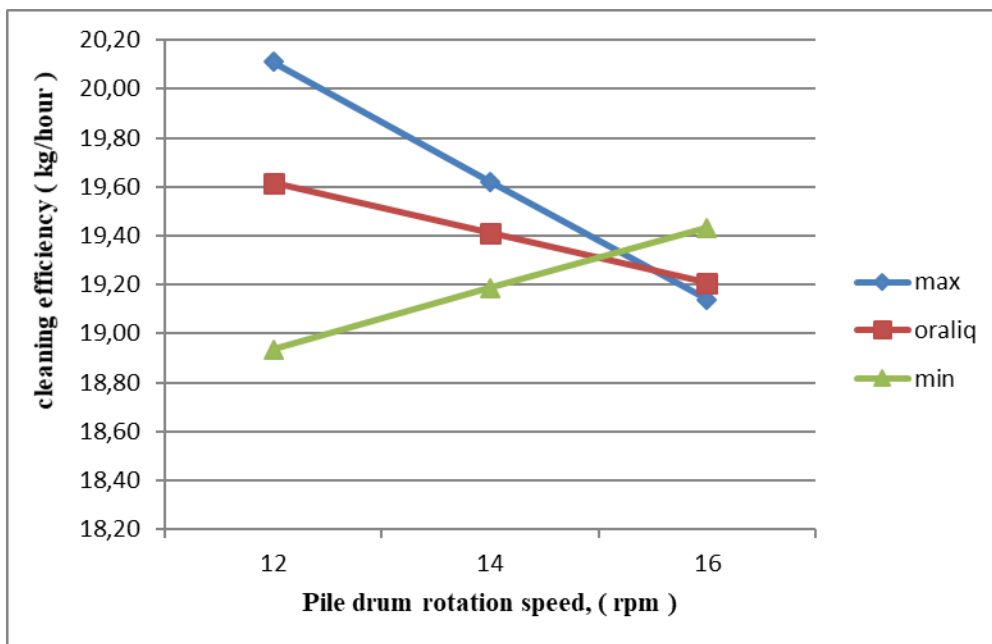

Figure 5. Graph of the dependence of the rotation speed of the pile drum on the cleaning efficiency.

Figure 5 shows a graph of the dependence of the speed of the pile drum on the cleaning efficiency, according to which it can be seen that in the first line it decreased from 20.1 kg/h to 19.1 kg/h, in the second line it decreased from 19.6 kg/h to 19.2 kg/h, and in the third line it increased from 18.9 kg/h to 19.4 kg/h.

CONCLUSION

The new adjustable design of the wool cleaning machine is very compact and is of great importance. It is very important to improve machines designed primarily for cleaning coarse wool. The results of the experi-

ments conducted with this new design of the adjustable cleaning machine are positive. In conclusion, the use of this machine significantly increases the efficiency of raw material cleaning. It separates foreign impurities and unsuitable fibers from the raw material. As a result of using the improved machine, it is possible to effectively save electricity.

List of used literature

1. Ismailov F, Kuldashev E, Abrorov A, Ismailov I, Bozorov R Improvement of the machine for wool scutching for obtaining ecologically clean fiber E3S Web of Conferences 390, 01010 (2023)
2. Abrorov A, Kuvoncheva M, Ismoyilov F, Fayziev S, Mukhammadov M Computational analysis of multivariant physical and mechanical experiments on laser hardening of gin disc saws Journal of Physics: Conference Series 2573 (2023) 012038
3. FB Ismayilov, EI Kuldashev, NN Sattarova and RR Bozorov Significance of using a screw cleaner at pretreatment of wool AIP Conf. Proc. 2969, 060029 (2024)
4. Khakimov Sh, Sayfullayev S, Ismaililov F, Tursunov H, Abrorov A. Theoretical research of the improved condenser device used in technology of lint separation. E3S Web of Conferences 548, 03020 (2024).
5. Smith, J., & Zhang, X. (2021). Design and Optimization of Wool Cleaning Machines: Technological Innovations and Performance Indicators. *Textile Technology Journal*, 34(2), 112-124.
6. Zhao, H., & Tan, L. (2022). Ultrasonic-Assisted Wool Cleaning: Enhancements in Machine Design and Technological Indicators. *Textile Processing and Technology Review*, 41(3), 158-169.
7. Zhang, H., & Li, X. (2023). Automation and Artificial Intelligence in Wool Cleaning Machines: Future Directions and Performance Metrics. *Journal of Textile Automation*, 10(1), 45-58.
8. Jones, R., & Li, K. (2020). Improved Wool Cleaning Methods Using Laser Technology: Technological Advances and Operating Principles. *Textile Innovations Journal*, 52(4), 231-245.

Proofreader: Zokir ALIBEKOV

Layout and Designer: Oloviddin Sobir ugli

2025. № 8

© When materials are reproduced, the INNOVATION SCIENCE AND TECHNOLOGY journal must be cited as the source. Authors are responsible for the accuracy of the information in materials and advertisements published in the journal. Editorial opinions may not always align with those of the authors. Submitted materials will not be returned to the editorial office.

To publish articles in this journal, you may submit articles, advertisements, stories, and other creative materials through the following links. Materials and advertisements are published on a paid basis.

You may subscribe to the journal at any time using the following details. Once subscribed, please send a screenshot or photo of your payment confirmation to our Telegram page @iqtisodiyot_77. Based on this, we will send the latest issue of the journal to your address each month.

“The journal “INNOVATION SCIENCE AND TECHNOLOGY” has been registered by the Agency for Information and Mass Communications under the Administration of the President of the Republic of Uzbekistan from 09.10.2024 under the registration number №390637. License number: C-5669633. PNFL: 30407832680027

Our address: Tashkent city, Yunusobod district, 19th block,
House 17.



Acceptance of articles

Published every
monthly



Directions

Social, economic, political,
technological, scientific



Scopus || Scientific electronic journal specializing in Scopus

CERTIFICATE NUMBER: №390637

**ORDER NUMBER ACCORDING TO
THE LICENSE REGISTER: C-5669633**

CONTACT:



Contact us
+998 97 748 70 03



Telegram channel
t.me/scopus_IST2100



Journal official website
<https://ist-journal.uz/index.php/IST>